

### Eagle Quantum Premier® (EQP) Controller EQ300X

#### DESCRIPTION

The Eagle Quantum Premier® Controller is a microprocessor based module that performs all the communication and control functions for the fire and gas system. The controller is approved as an annunciation and releasing device for fire alarm systems.

The Local Operating Network/Signaling Line Circuit (LON/SLC), through which all field devices communicate, starts and ends its loop at the Controller. The Controller continuously monitors the field devices on the LON/SLC and performs the logic functions needed to generate the appropriate output(s).

The Controller performs both static and user programmable logic operations. Static logic activates built-in annunciation circuits, consisting of both visible and audible alarms, per ANSI NFPA 72.

Programmable logic allows the Controller to be customized to perform a variety of complex logic operations. Using Det-Tronics Safety System Software (S<sup>3</sup>), the Controller can be programmed to implement any cross-zone monitoring, voting, or timed operations that might be needed in a fire suppression system.

#### FEATURES

- Approved annunciation and releasing device per NFPA 72
- Meets FM/CSA guidelines as an approved gas system
- SIL 2 approved model available
- Redundant controller capability
- Programmable logic
- Utilizes MODBUS and Allen Bradley ControlNet protocols
- Four-line, 20 character alphanumeric display
- LED status indicators
- Fault tolerant communication loop
- Extensive built-in diagnostics
- Supports up to 246 field devices
- FM/CSA/ATEX/CE
- Model available with US Coast Guard type approval under 46 CFR 161.002



#### REDUNDANCY

Two EQP controllers can be configured as a redundant pair, thereby increasing the availability of the system. The controllers work in “Master” and “Hot Standby” mode. Under normal operating conditions, the Standby controller receives the same inputs and update information as the Master, but has no control over the outputs and does not execute user logic. In the event of a switchover, a bumpless transfer occurs. Controller redundancy offers the following features:

- Automatic configuration of the standby controller
- Bumpless transfer
- Forced and automatic switchover
- No downtime on controller replacement
- Automatic synchronization between controllers
- Increased system availability.

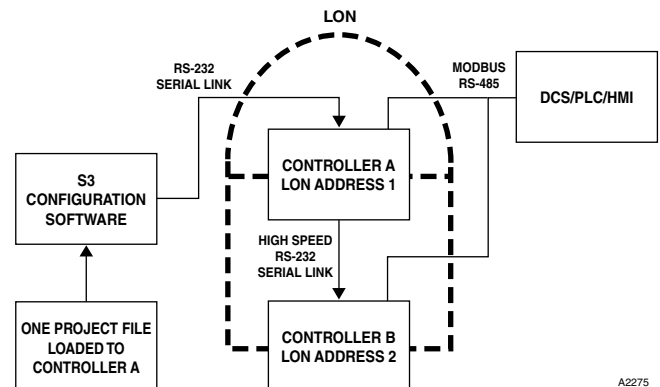

Figure 1—Block Diagram of EQP System with Redundant Controllers

## SPECIFICATIONS

### INPUT VOLTAGE—

24 Vdc nominal, 18 to 30 Vdc. 10% overvoltage will not cause damage to the equipment.

### POWER REQUIREMENTS—

9 watts nominal, 12 watts maximum.

### I/O PORTS—

The Controller provides two electrically isolated serial ports, which can be active simultaneously. Port 1 is a RS-232 port used for system configuration. Port 2 is a RS-485 port that supports MODBUS RTU protocol.

An optional dual media ControlNet board is available. This provides a ControlNet interface, which enables users to monitor status information as well as configure various controller parameters.

### SERIAL INTERFACE BOARD (Optional)—

An optional serial board supports up to three additional serial ports. For a redundant controller configuration, the board is required in both controllers.

### UNSUPERVISED OUTPUTS (8 Relays)—

Dry Contact Rating: 1 ampere at 30 Vdc maximum. SPDT normally open/normally closed contact, configurable for normally energized or de-energized (de-energized is the default mode).

### TROUBLE OUTPUT—

SPDT normally open/normally closed contact. Non-configurable, normally energized only.

### RELAY RESPONSE TIME—

Output relays actuate in <0.1 second after acknowledging an alarm command message.

### UNSUPERVISED DIGITAL INPUTS (8 Channels)—

Two state input (on/off).

### TEMPERATURE RANGE—

Operating: -40°F to +185°F (-40°C to +85°C).  
Storage: -40°F to +185°F (-40°C to +85°C).  
Excluding communication port optional modules.

### HUMIDITY RANGE—

0 to 95% RH, non-condensing.

### MOUNTING—

DIN rail or panel mount specified at the time of order.

### VIBRATION—

Meets FM 3260, ANSI/ISA 12.13.01, CSA C22.2 #152, EN61779-1.

### CERTIFICATION—

FM / CSA: Class I, Div. 2, Groups A, B, C, D (T4).  
Class I, Zone 2, Group IIC (T4).  
Performance verified.

IEC 61508: Safety Approved  
SIL 2 Capable

ATEX / CE: ATEX/EMC Directive Compliant.  
Performance verified per EN 61779-4.

CE 0539 II 3 G

EEx nC IIC T4

DEMKO 02 ATEX 133867U

T4 (Tamb = -40°C to +85°C).



Special conditions for safe use:

The device shall be installed in an enclosure that complies with all relevant requirements of EN 50021: 1999, and provides a degree of ingress protection of at least IP54. The device may only be installed, connected or removed when the area is known to be non-hazardous.

### SHIPPING WEIGHT (Approximate)—

5 pounds (2.3 kilograms).

### DIMENSIONS—

See Figure 2.

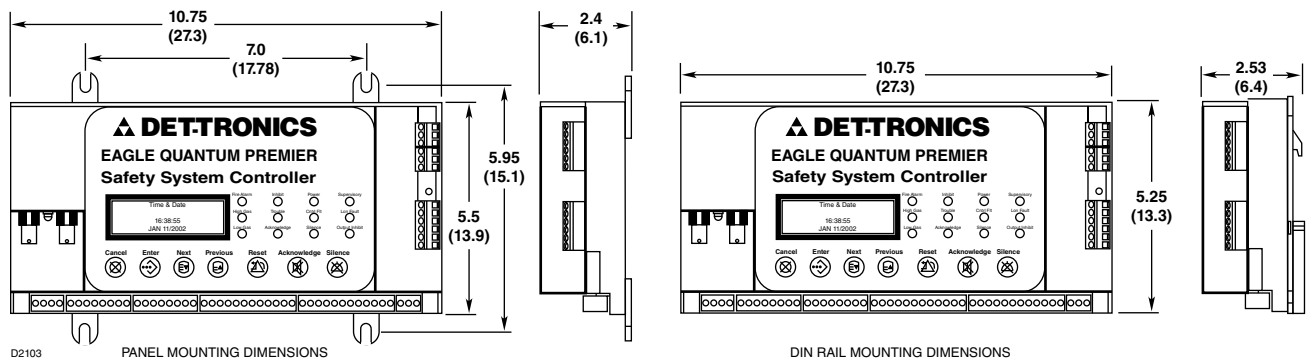

Figure 2—Dimensions of Controller in Inches (Centimeters)

Specifications subject to change without notice.

Det-Tronics, the DET-TRONICS logo, and Eagle Quantum Premier are registered trademarks or trademarks of Detector Electronics Corporation in the United States, other countries, or both. Other company, product, or service names may be trademarks or service marks of others.

©Copyright Detector Electronics Corporation 2009. All rights reserved.



## Detector Electronics Corporation

6901 West 110th Street • Minneapolis, Minnesota 55438 USA

Operator: (952) 941-5665 or (800) 765-FIRE

Customer Service: (952) 946-6491 • Fax (952) 829-8750

http://www.det-tronics.com • E-mail: det-tronics@det-tronics.com